

BRECObasic® - Timing Belts

Simple. Good. Reliable.

Program expansion

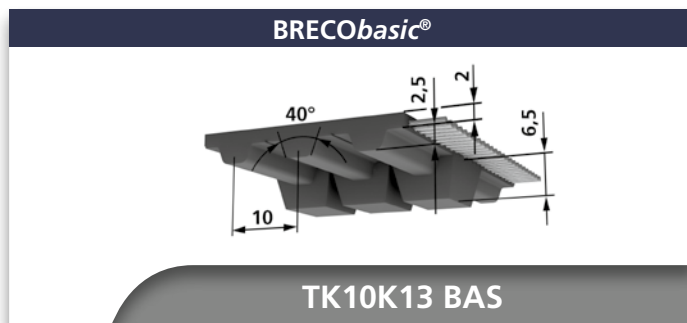

BRECO® TK10K13 BAS (M/V)				Specific tooth force	
R.p.m. n [min ⁻¹]	F _{tspez} [N/cm]	R.p.m. n [min ⁻¹]	F _{tspez} [N/cm]	R.p.m. n [min ⁻¹]	F _{tspez} [N/cm]
0	50,50	1200	29,30	3600	20,70
20	49,00	1300	28,70	3800	20,30
40	47,70	1400	28,20	4000	19,86
60	46,60	1500	27,60	4500	18,91
80	45,70	1600	27,10	5000	18,06
100	44,80	1700	26,70	5500	17,28
200	41,40	1800	26,20	6000	16,58
300	39,10	1900	25,80	6500	15,93
400	37,20	2000	25,40	7000	15,33
500	35,70	2200	24,60	7500	14,76
600	34,40	2400	23,90	8000	14,24
700	33,30	2600	23,30	8500	13,74
800	32,40	2800	22,70	9000	13,28
900	31,50	3000	22,20	9500	12,84
1000	30,70	3200	21,70	10000	12,42
1100	30,00	3400	21,20		

Belt widths b [mm]	TK10K13 BAS		
Production widths [mm]	32	50	100

BRECObasic® - Timing Belts

Simple. Good. Reliable.

TK10K13 BAS (M/V)	Available lengths and versions	
Standard delivery lengths (M)	50 or 100-metre roll	
Belt colour	anthracite	
Minimum length joined (V)	1000 mm	request minimum order value
PAZ	available	

BRECObasic® 50 TK10K13 BAS 50000 M			
Width b			
Type/pitch			
Length in mm			
By-the-metre product			

TK10K13 BAS (M/V)		Admissible tension cord strength F_{Tzul} / Specific elasticity / Belt weight			
Belt width	b [mm]	32	50	100	
M	Basic tension member	F_{Tzul} [N]	2600	4200	8600
	Specific elasticity	C_{spez} [N]	$7,0 \cdot 10^5$	$11,0 \cdot 10^5$	$22,0 \cdot 10^5$
V	Basic tension member	F_{Tzul} [N]	1300	2100	4300
Belt weight	[kg/m]	0,282	0,407	0,735	

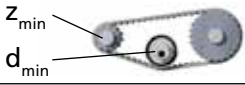
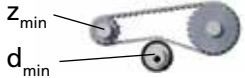
TK10K13 BAS (M/V)		Flexibility (minimum diameter)		
			M	V
	Without contraflexure	z_{min}	25	25
		d_{min} [mm]	80	80
	With contraflexure	z_{min}	25	25
		d_{min} [mm]	80	80

